

Gas Industry Standard

GIS/E17-2:2018

Specification for

Insulation joints

Part 2: Joints operating at pressures not greater than 7 bar



Contents

	Page
Foreword	iii
Mandatory and non-mandatory requirements	iii
Disclaimer	iii
Brief history	iv
1 Scope	1
2 Normative references	1
3 Terms and definitions	2
4 Materials	2
5 Design	3
6 Manufacture	3
7 Testing	4
8 Marking	6
9 Painting and protection	6
10 Handling and transport	6
11 Documentation	7
Annex A (informative) Bibliography	8
Annex B (normative) Toroidal sealing rings (“O”-rings) conforming to BS 4518	9
Annex C (normative) Typical data sheet for insulation joints conforming to GIS/E17-2	10
Annex D (normative) Resistance to torsion	11
Figure B.1 — Toroidal sealing rings (“O”-rings) conforming to BS 4518	9
Table D.1 — Torque test values	11

Foreword

Gas Industry Standards (GIS) are revised, when necessary, by the issue of new editions. Users should ensure that they are in possession of the latest edition. Contractors and other users external to Gas Transporters should direct their requests for copies of a GIS to the department or group responsible for the initial issue of their contract documentation.

Comments and queries regarding the technical content of this document should be directed in the first instance to the contract department of the Gas Transporter responsible for the initial issue of their contract documentation.

This standard calls for the use of procedures that may be injurious to health if adequate precautions are not taken. It refers only to technical suitability and does not absolve the user from legal obligations relating to health and safety at any stage.

Compliance with this engineering document does not confer immunity from prosecution for breach of statutory or other legal obligations.

Mandatory and non-mandatory requirements

For the purposes of a GIS the following auxiliary verbs have the meanings indicated:

- can** indicates a physical possibility;
- may** indicates an option that is not mandatory;
- shall** indicates a GIS requirement;
- should** indicates best practice and is the preferred option. If an alternative method is used then a suitable and sufficient risk assessment needs to be completed to show that the alternative method delivers the same, or better, level of protection.

Disclaimer

This engineering document is provided for use by Gas Transporters and such of their contractors as are obliged by the terms of their contracts to comply with this engineering document. Where this engineering document is used by any other party, it is the responsibility of that party to ensure that the engineering document is correctly applied.

Brief history

<p>First published as BGC/PS/E17: Part 2 Amendment No.1 published Amended issue (harmonized with Parts 1 and 3) published as GBE/E17: Part 2 Editorial update to reflect demerger November 2000 Editorial update to comply with GRM Edited by BSI in accordance with BS 0-3:1997 Reviewed and updated to include torsion and high temperature resistance requirements Reviewed 2023</p>	<p>November 1985 May 1992 January 1994 June 2001 August 2004 August 2006 March 2018 April 2023</p>
--	---

© **ENA**, on behalf of Cadent Gas Limited, Northern Gas Networks, SGN, and Wales & West Utilities.

This Gas Industry Standard is copyright and must not be reproduced in whole or in part by any means without the approval in writing of either Cadent Gas Limited, Northern Gas Networks, SGN, or Wales & West Utilities.

1 Scope

This Gas Industry Standard specifies requirements for pressure-rated insulation joints of all sizes operating on natural gas at pressures not greater than 7 bar and normally in the temperature range -20 °C to 50 °C.

This standard also covers insulation joints used on gas service & riser pipe installations not greater than 7 bar maximum operating pressure whether screwed conforming to BS 1387, welded or flanged using steel pipe from ½" to 2" nominal bore.

This standard also refers to transition insulation joints (steel to ductile iron) where the working pressure is related to that of the gas mains.

This standard does not cover insulators for insulation joints using insulated flanges.

Insulation joints manufactured to the requirements of this standard may be used for the electrical insulation of pipework and/or for cathodic protection applications. Insulation joints serve to minimize the flow of electricity through metallic gas pipework. The fittings have two metallic halves separated by a ring of non-electrically conducting material.

It is important that insulation joints are fitted in the best location for their operation, and as a general rule, this requires them to be located as close as possible to the position where the gas pipework enters the building. Insulation joints are required on all steel services and on polyethylene services that have a steel tail. It is not necessary to fit an insulation joint on a service where the polyethylene pipe continues above ground.

2 Normative references

The following referenced documents are indispensable for the application of this document. For dated references, only the edition cited applies. For undated references, the latest edition of the referenced document (including any amendments) applies.

Formal standards

BS 4518, *Specification for metric dimensions of toroidal sealing rings ('O'-rings) and their housings.*

BS EN 682, *Elastomeric seals - Materials requirements for seals used in pipes and fittings carrying gas and hydrocarbon fluids.*

BS EN 1092-1, *Flanges and their joints. Circular flanges for pipes, valves, fittings and accessories, PN designated Steel flanges.*

BS EN 1759-1, *Flanges and their joints. Circular flanges for pipes, valves, fittings and accessories, class-designated. Steel flanges, NPS 1/2 to 24.*

BS EN 10216-1, *Seamless steel tubes for pressure purposes - Technical delivery conditions.*

BS EN 10217-1, *Welded steel tubes for pressure purposes - Technical delivery conditions — Non-alloy steel tubes with specified room temperature properties.*

BS EN 10226-1:2004, *Pipe threads where pressure tight joints are made on the threads — Taper external threads and parallel internal threads — Dimensions, tolerances and designation.*

BS EN 10253-1, *Butt-welding pipe fittings — Wrought carbon steel for general use and without specific inspection requirements.*

BS EN 10255, *Non-alloy steel tubes suitable for welding and threading.*

American Petroleum Institute (API) Standard

API 5L, *Specification for line pipe.*

3 Terms and Definitions

For the purposes of this document, the following definitions apply.

3.1

contractor

the person, firm or company with whom the gas transporter enters into a contract to which this standard applies, including the contractor's personal representatives, successors and permitted assigns

3.2

insulation joint

a special component consisting of two metal pipes insulated from each other using materials and seals in such a way that the pipes are mechanically connected but electrically insulated from one another

NOTE From this point on, "insulation joint" is referred to simply as "joint".

4 Materials

4.1 Materials for metallic components

Materials of manufacture shall conform to the relevant gas industry standard. Other national or international standards may be acceptable provided that their equivalence with gas industry standards can be demonstrated.

4.2 Materials for non-metallic components

4.2.1 All non-metallic insulating materials in the joint shall be capable of withstanding temperature conditions likely to be encountered in service as specified in Clause 1. Higher transient temperatures may occur during welding, in the manufacture of the joint or in connection of the pipe; joints subject to welding operations shall contain materials that are resistant to resultant temperature transients.

4.2.2 All materials shall be resistant to the action of water, hydrocarbons, glycols, methanol, natural gas and odorant.

4.2.3 Where toroidal sealing rings ("O"-rings) are used to effect a pressure seal, the "O"-rings shall be made from an elastomer-based material having a high resistance to compression set. The "O"-rings shall be of moulded construction and preferably continuous. A single scarf joint is permissible provided it is adequately bonded and the manufacturer can show that the required "O"-ring tolerances specified in Annex B are maintained throughout. Scarf-jointed "O"-rings are not permissible for joints less than 80 mm nominal size.

The dimensions and tolerances of the associated grooves shall be in accordance with BS 4518, where appropriate. For sizes not covered by BS 4518, the contractor shall submit details of the dimensions and tolerances of the associated grooves, for the approval of the gas transporter.

Tolerances on "O"-ring flash, mismatch, offset and flats shall not exceed the limits specified in BS 4518 (see Annex B).

4.2.4 All elastomers contained in the joint shall be of ageing resistant material having a residual elasticity suitable for ensuring permanent leak tightness (see **4.2.3** and Annex C). The requirements of BS EN 682 shall apply.

4.2.5 The insulating materials and seals in the joint shall be suitable for resisting the electrical test voltage specified in **7.3**.

5 Design

5.1 The joint shall be designed to provide an effective barrier in service.

5.2 The joint shall be adequate to withstand the testing specified in Clause 7.

5.3 The design of the joint shall be such that the seals are contained within the joint in such a way as to prevent:

- a) damage to the seals during assembly;
- b) damage to the seals by extrusion during the relevant pressure test specified in **7.1** or **7.2**;
- c) leakage during the relevant pressure test specified in **7.1** or **7.2**;
- d) leakage during the relevant combined pressure/bending test in **7.4.2a)** or b).

5.4 The contractor shall state on the data sheet (see Annex C, "section two") the overall length of the joint and the actual bore of the joint.

5.5 When the joint is assembled there shall be no recesses within the bore that may trap debris.

All inner cavities of the joint shall be filled with low viscosity dielectric materials, such as rubber and epoxy resin which solidify on curing. Precautions shall be taken to prevent the inclusion of air and foreign bodies in the dielectric materials.

5.6 The bore of the joint shall be lined with a coating having high electrical resistance to prevent a reduction in electrical resistance across the joint through debris bridging the joint insulation ring.

The coating shall extend the full length of the joint but shall not bridge the insulation ring of the joint bore.

5.7 The joint shall be thoroughly dried out after hydrostatic pressure testing, before the subsequent application of dielectric filler into the joint cavities and the bore of the joint lined with a protective coating.

6 Manufacture

6.1 The contractor's manufacturing procedures and inspection systems shall ensure that the products supplied conform in all respects to the requirements of this standard.

6.2 At the time of tendering, the contractor shall supply:

- a) general arrangement drawings together with overall dimensions;
- b) completed data sheets (see Annex C).

6.3 When a joint has not received prior design approval from the gas transporter, or at the request of the gas transporter, the contractor shall supply, where appropriate, the following additional information at the time of tendering:

- a) detailed sectional arrangement drawings showing all parts with reference numbers and materials identified;
- b) full details of manufacturing procedures, including levels of end loads, if appropriate;
- c) fabrication details;
- d) welding (where applicable) and testing procedures;
- e) installation and maintenance recommendations.

6.4 Once a joint has received design approval from the gas transporter, any changes in materials, design or manufacture shall be notified to the gas transporter and written approval obtained prior to tendering.

6.5 The manufacturing procedures to be followed in the production of the joints shall be recorded and submitted to the gas transporter for approval.

6.6 The gas transporter shall state, on the data sheet, the type of end preparation required, i.e. end connections shall be either butt weld ends, plain ends, threaded ends or ductile iron spigot ends.

7 Testing

7.1 Pressure testing (nominal sizes not greater than 450 mm)

7.1.1 All joints not greater than 450 mm nominal size shall be pneumatically- or hydrostatically- pressure tested to 10.5 bar and held for a period of not less than 3 min, except for joints not greater than 80 mm nominal size where sample testing may be acceptable when an approved quality control system is in operation.

7.1.2 Joints may be tested either individually or welded together in any number.

7.1.3 Pressure sealing methods shall be carried out through the use of plugs (screwed or expandable), end caps (screwed or welded) or internal spool pieces. End sealing methods which subject the joint to axial compression shall not be used.

7.1.4 The test shall be considered satisfactory if there are no visible signs of air leakage. Checking for leakage shall be carried out by normal leak detection techniques.

7.1.5 All equipment used for pressure measurement shall be covered by a current test certificate.

7.1.6 Adequate safety precautions shall be taken during any pneumatic pressure testing.

7.2 Pressure testing (nominal sizes greater than 450 mm)

7.2.1 All joints greater than 450 mm nominal size shall be hydrostatically-pressure tested to a test pressure of 10.5 bar and held for a period of not less than 1 h.

There shall be no signs of water leakage nor any drop in pressure during the test period. Failures shall be investigated and rectified before re-testing.

7.2.2 Joints may be tested either individually or welded together in any number. End sealing shall be carried out through the use of expandable plugs or welded end caps.

7.2.3 All equipment used for pressure measurement shall be covered by a current test certificate.

7.3 Electrical testing

7.3.1 General

Immediately after pressure testing, the completed joints shall be subjected to the insulation and resistance tests specified in **7.3.2** and **7.3.3** respectively. Heat shall not be used as a means of forced drying. Care shall be taken to ensure contact is made on bare metal during electrical testing.

7.3.2 Insulation test

An insulation test of the joint shall be applied at a voltage of not less than 2 kV using a voltage of substantially sine waveform at a frequency of 50 Hz to 60 Hz for a period of 1 min. No flashover or breakdown shall occur during the test.

7.3.3 Resistance test

A resistance test using a 500 V insulation tester shall be applied. The resistance shall be not less than 5 M Ω .

7.4 Prototype testing

7.4.1 Where prototype tests are specified in the invitation to tender, they shall be carried out as specified in **7.4.2**, **7.4.3** and **7.4.4**.

7.4.2 Resistance to internal pressure and bending

Combined internal pressures and externally applied bending load tests shall be carried out as follows.

- a) Joints equal to or greater than 80 mm nominal size shall be capable of resisting a simultaneously applied internal pressure of 15 bar and externally applied bending load sufficient to induce a bending stress of 100 % specified minimum yield stress (SMYS) in the adjoining pipe conforming to Grade B of API 5L, steel 410, i.e. 410 N/mm² (34 000 lbf/in²), conforming to BS EN 10216-1 and BS EN 10217-1 or screwed steel pipe conforming to BS EN 10255.
- b) Joints not greater than 80 mm nominal sizes shall be capable of resisting a simultaneously applied internal pressure of 15 bar and externally applied bending load sufficient to induce a bending stress of 100 % SMYS in the adjoining pipe. The bending load shall be so applied by four-point loading that a constant bending moment is applied throughout the length of the joint.

Where the joint has a screwed end for fitting it to the adjacent pipe, then this test may be reduced to 60% SMYS (since the threads will fail at about 68% SMYS) provided that alternative evidence is provided to demonstrate that the joint is capable of resisting a bending load of 100%.

7.4.3 Resistance to torsion

The joint shall not separate or unscrew when subjected to a torque applied in either direction. The test requirement is specified in Annex D.

Following completion of this test the joint shall be pressure tested in accordance with **7.1** or **7.2** as applicable.

The resistance to torsion requirement shall be deemed to be met by conformance with Annex D followed by conformance with **7.1** or **7.2** as applicable.

7.4.4 Resistance to high temperature

Where the joint is intended for use on a service pipe or as part of a riser system on a multi-occupancy building, then it shall retain its leak-tightness under a temperature of 650 °C for a duration of 30 minutes.

The high temperature resistance test should be carried out with the test joint secured vertically with its outlet port capped, in a preheated furnace at the test temperature of 650 °C. The test assembly shall be pressurised using nitrogen to the test pressure of 100 mbar immediately after being placed in the oven. The temperature of the fitting shall be measured

at its surface using a calibrated thermocouple, and the test will commence once the fitting is pressurised to 100 mbar and the fitting surface temperature reaches 650 °C. The test pressure and temperature shall be maintained for 30 minutes, during which time the fitting is monitored for any leaks. The fitting is considered to have passed the test if there is no leakage of gas during the 30 minutes dwell time.

8 Marking

8.1 All joints supplied in accordance with this standard shall be suitably and individually identified using methods of marking approved by the gas transporter.

8.2 Joints conforming to this standard shall be permanently marked with the following information:

- a) serial number and date;
- b) nominal size;
- c) pressure rating;
- d) quality assurance engineer's acceptance stamp;
- e) relevant gas transporter order number;
- f) the number and date of this standard, i.e. GIS/E17-2:2018 ¹⁾;
- g) where applicable, rated to 650 °C for 30 minutes.

NOTE Attention is drawn to the advantages of using third party certification of conformance to a standard.

8.3 For joints which, due to their size or number, cannot be individually identified as specified above, a tagging/bagging identification method, approved by quality assurance, shall be used.

9 Painting and protection

9.1 After the satisfactory completion of all electrical and pressure testing, all external surfaces of the complete assembly shall be protected as specified on the data sheet (see Annex C, "section one"). Care shall be taken to ensure that paint does not enter any threads.

9.2 Machined faces shall be protected with an approved rust preventative or approved corrosion inhibitor that can easily be removed on site, i.e. by non-toxic solvents or wire brushing.

10 Handling and transport

10.1 It is the contractor's responsibility to ensure that packaging is adequate to prevent mechanical damage during handling and transport. The ends shall be fitted with an approved protective device to prevent mechanical damage when loading, unloading and in transit. The ends of all joints shall be sealed to prevent the ingress of dirt or moisture.

10.2 Care shall be taken to ensure that wire ropes or chains, etc., do not come into metallic contact with the joint. It is recommended that broad band non-metallic slings be used to load, unload and support joints when in transit.

¹⁾ Marking GIS/E17-2:2018 on or in relation to a product represents a manufacturer's declaration of conformity, i.e. a claim by or on behalf of the manufacturer that the product meets the requirements of the standard. The accuracy of the claim is therefore solely the responsibility of the person making the claim. Such a declaration is not to be confused with third party certification of conformity, which may also be desirable.

10.3 During transit, joints shall be adequately supported and, where chains or wire ropes are used to secure the joint, they shall not come into contact with the joint or pups. Damage to joints by the use of chains or wire ropes, etc., shall be cause for rejection.

Joints equal to or greater than 300 mm nominal size shall be adequately supported on pallets. Smaller joints shall be suitably packaged. In all instances, joints shall be prepared for transit so that they are not in direct contact with one another.

11 Documentation

Records shall be retained by the manufacturer for 5 years from the date of manufacture. These records shall include the following:

- a) details of chemical analysis required for materials together with results from pressure tests, electrical tests and mechanical tests (certificates of conformity based on **4.1**);
- b) manufacturing and welding procedures.

Where the insulation joint has an end intended for welding to it to the adjacent pipe then a copy of these records must be supplied to the customer.

Annex A (informative)

Bibliography

Formal standards

BS EN 10226-1:2004, *Pipe threads where pressure tight joints are made on the threads — Taper external threads and parallel internal threads — Dimensions, tolerances and designation.*

BS EN 10253-1, *Butt-welding pipe fittings — Wrought carbon steel for general use and without specific inspection requirements.*

BS EN 10255, *Non-alloy steel tubes suitable for welding and threading.*

Gas Industry Standards

GIS/F/7, *Specification for steel welding pipe fittings 15 mm to 450 mm nominal size for operating pressures not greater than 7 bar.*

GIS/L/2, *Steel pipes 21.3 mm to 1 219 mm outside diameter for operating pressures up to 7 bar.*

Annex B (normative)
Toroidal sealing rings ("O"-rings) conforming to BS 4518

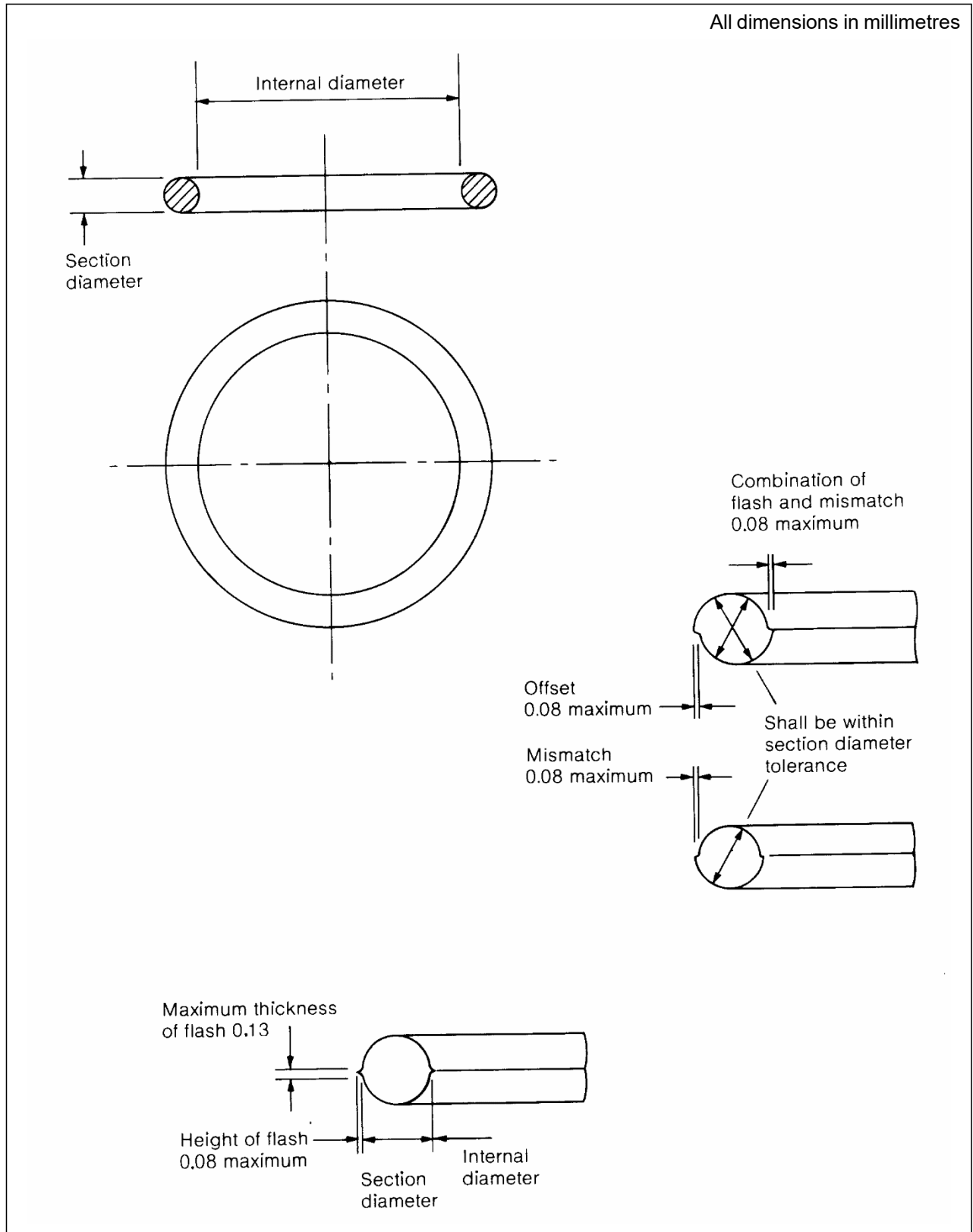

Figure B.1 — Toroidal sealing rings ("O"-rings) conforming to BS 4518

Annex C (normative)
Typical data sheet for insulation joints conforming to GIS/E17-2

Standard data sheet for insulation joints to GIS/E17-2			
Section 1 – to be completed by gas transporter			
1. Gas transporter enquiry/order number Lot number			
2. Joint manufacturer/supplier			
3. Joint nominal size in mm			
4. Joint end preparation – please tick one box for each end in the following table.			
Material	End preparation	End 1	End 2
Steel	Flanged to BS EN 1092-1 (Table PN16 flange)	<input type="checkbox"/>	<input type="checkbox"/>
Steel	Flanged to BS EN 1759-1 (class designated flange)	<input type="checkbox"/>	<input type="checkbox"/>
Steel	Square	<input type="checkbox"/>	<input type="checkbox"/>
Steel	BS EN 10226: screwed externally	<input type="checkbox"/>	<input type="checkbox"/>
Steel	BS EN 10226: screwed internally	<input type="checkbox"/>	<input type="checkbox"/>
Steel	Screwed other ^{a)}	<input type="checkbox"/>	<input type="checkbox"/>
Ductile iron	Plain	<input type="checkbox"/>	<input type="checkbox"/>
Ductile iron	Grooved	<input type="checkbox"/>	<input type="checkbox"/>
^{a)} Please state details of screwed other.			
5. Protective finish			
Manufacturer's finish <input type="checkbox"/> please state details			
Other <input type="checkbox"/> please specify finish			
6. Is fire resistance required in accordance with clause 7.4.4? <input type="checkbox"/>			
List any special requirements below:			
7.			
8.			
Section 2 – to be completed by the contractor			
9. Overall length of joint in mm			
10. Actual bore of joint in mm			
11. Manufacturer's standard drawing number			
Plant/project	Data sheet number	Sheet of	

Annex D (normative) Resistance to torsion

D.1 Apparatus

D1.1 Torque wrench or alternative machine/equipment, with suitable sockets to apply torque to a range of fittings.

D1.2 Bench vice or an alternative suitable clamping tool, capable of securing the fittings in a fixed position.

D.2 Test Sample

A new sample shall be used for each test.

D.3 Procedure

If required, suitable time should be allowed for fittings to be fully cured before testing.

If the fitting has different inlet sizes then apply the torque to the smaller size.

Clamp one side of the fitting. In the case where there is a difference in inlet sizes the side with the larger inlet diameter is to be clamped. The appropriate torque is then applied to the other side of the fitting.

Repeat the test on another sample in the opposite direction.

D.2 Test results

Depending on the connection size, the valve shall resist the stresses of torque specified in Table D.1.

Nominal inlet size		Torque
In	mm	N·m
1/8	6	15
1/4	8	20
3/8	10	35
1/2	15	50
3/4	20	85
1	25	125
1 1/4	32	160
1 1/2	40	200
2	50	250

Table D.1 — Torque test values